

Quantum geometric tensor determines  
the i.i.d. conversion rate  
in the resource theory of asymmetry  
for any compact Lie group

Koji Yamaguchi  
Kyushu University

Joint work with Yosuke Mitsuhashi, Tomohiro Shitara, and Hiroyasu Tajima

[[KY](#), Y. Mitsuhashi, T. Shitara, and H. Tajima arxiv:2411.04766]

# Introduction & Overview

- IID state conversion theory
  - a central question in resource theory
  - provides foundations for manipulating and quantifying resources
- The resource theory of asymmetry (RTA)
  - resource theory for quantifying symmetry breaking, including coherence
- We establish the IID pure-state conversion theory in RTA for any compact Lie group
- Application: The resource requirement for asymptotic state conversion in quantum thermodynamics

# IID conversion theory

A key problem in resource theories: asymptotic IID conversion theory

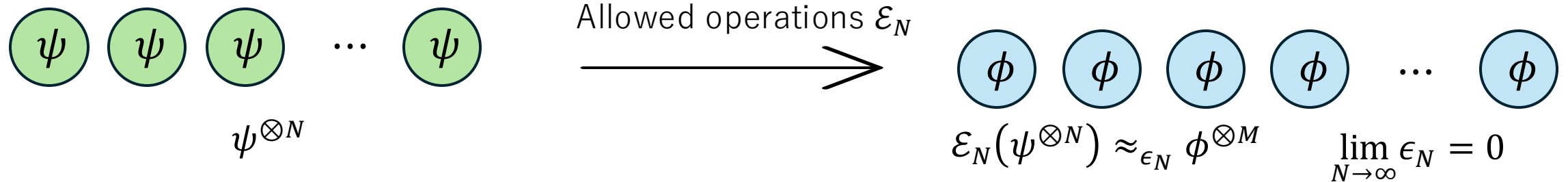

Conversion rate :  $R(\psi \rightarrow \phi) := \sup\{\text{conversion rate achievable with allowed operations}\}$

Why important? Because it addresses central questions:

- How to transform resource states?
- How to quantify resource?

Cf.) Entanglement theory: IID conversion rate via LOCCs  $R(\psi \rightarrow \phi) = \frac{S_{EE}(\psi)}{S_{EE}(\phi)}$

This fact establishes entanglement entropy as a standard measure of entanglement.

**Establishing the IID theory in RTA identifies a standard measure of symmetry breaking.**

# What is asymmetry (symmetry breaking)?

Energy coherence: superposition between energy eigenstates with different energy levels.

$$\text{Ex.) coherence bit } |+\rangle = \frac{1}{\sqrt{2}}(|0\rangle + |1\rangle) \quad H = E|1\rangle\langle 1|$$

More abstractly, we say that a state has energy coherence if it is *not* invariant under time-translation

$$\rho \text{ is asymmetric under time-translation iff } \exists t \quad \mathcal{U}_t(\rho) \neq \rho \quad \mathcal{U}_t(\rho) := e^{-iHt}\rho e^{iHt}$$

In general, under a symmetry described by a group  $G$ ,

$$\begin{aligned} \rho \text{ is asymmetric iff } & \exists g \in G \quad \mathcal{U}_g(\rho) \neq \rho & \mathcal{U}_g(\rho) := U(g)\rho U(g)^\dagger \\ \rho \text{ is symmetric iff } & \forall g \in G \quad \mathcal{U}_g(\rho) = \rho & U : \text{projective unitary rep.} \end{aligned}$$

Resource Theory of Asymmetry (RTA) is a framework quantifying asymmetry(, including coherence).

# Free states and free operations in RTA

RTA is defined by

- Free states: symmetric states  $\rho$  s.t.  $\forall g \in G \quad \mathcal{U}_g(\rho) = \rho$
- Free operations:  $G$ -covariant operations  $\mathcal{E}$  is  $G$ -covariant  $\stackrel{\text{def.}}{\iff} \forall g \in G, \quad \mathcal{E} \circ \mathcal{U}_g = \mathcal{U}'_g \circ \mathcal{E}$

covariant Stinespring dilation

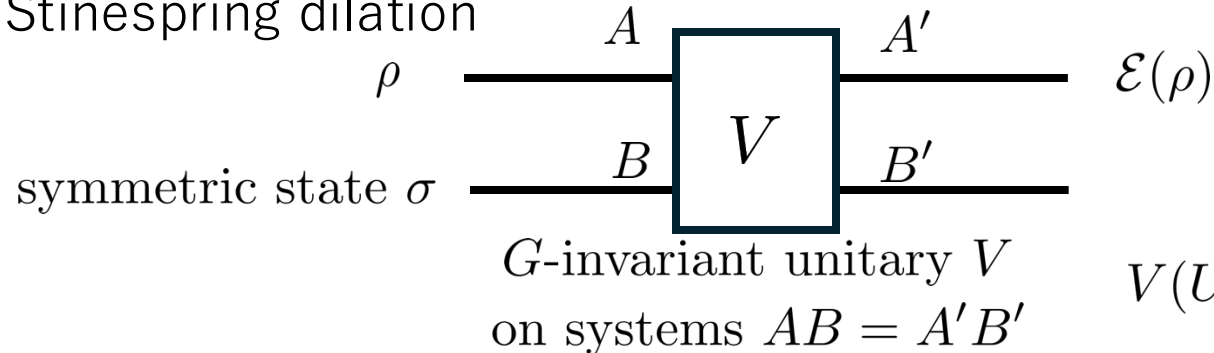

$$V(U_A(g) \otimes U_B(g)) = (U_{A'}(g) \otimes U_{B'}(g))V$$

This condition implies  $V(X_{A,\mu} + X_{B,\mu}) = (X_{A',\mu} + X_{B',\mu})V$   
 : conservation law

$\{X_\mu\}_{\mu=1}^{\dim G}$  : generators of infinitesimal transf.

- For example,
- time-translation symmetry:  $X = H$ , i.e., the Hamiltonian
  - $SO(3)$ -symmetry:  $X_i = L_i$ , i.e., angular momentum operators

# Main result: IID conv. theory in RTA

Quantum geometric tensor (QGT):

a matrix characterizing infinitesimal changes of a quantum state under parameter variations

[J. P. Provost and G. Vallee, Commun. Math. Phys. 6, 289 (1980)] [M. V. Berry, in *Geometric Phases in Physics*, 5 (1989)]

For pure states  $\mathcal{U}_g(\psi)$  parametrized by  $g \in G$ , the QGT  $\mathcal{Q}^\psi$  is a Hermitian matrix of  $\dim G \times \dim G$ ,

$$\mathcal{Q}_{\mu\nu}^\psi = \langle \psi | X_\mu X_\nu | \psi \rangle - \langle \psi | X_\mu | \psi \rangle \langle \psi | X_\nu | \psi \rangle \quad \{X_\mu\}_{\mu=1}^{\dim G} : \text{generators}$$

Theorem: conversion rate for pure states  $\psi$  and  $\phi$

In RTA for any connected compact Lie group  $G$ , if  $\text{Sym}_G(\psi) \subset \text{Sym}_G(\phi)$ ,

$\text{Sym}_G(\rho) := \{g \in G \mid \mathcal{U}_g(\rho) = \rho\}$  ( $\approx$  periods)

$$R(\psi \rightarrow \phi) = \sup\{r \geq 0 \mid \mathcal{Q}^\psi \geq r \mathcal{Q}^\phi\}$$

and otherwise  $R(\psi \rightarrow \phi) = 0$ .

[In our paper, formula is extended to any compact Lie group]

(cf.) In entanglement theory,  $R(\psi \rightarrow \phi) = \frac{S_{\text{EE}}(\psi)}{S_{\text{EE}}(\phi)} = \sup\{r \geq 0 \mid S_{\text{EE}}(\psi) \geq r S_{\text{EE}}(\phi)\}$

**In RTA, the QGT plays the same role as entanglement entropy does in entanglement theory.**

# Comparison with prior research

Theorem: conversion rate for pure states  $\psi$  and  $\phi$

In RTA for any connected compact Lie group  $G$ , if  $\text{Sym}_G(\psi) \subset \text{Sym}_G(\phi)$ ,

$$R(\psi \rightarrow \phi) = \sup\{r \geq 0 \mid Q^\psi \geq rQ^\phi\}$$

and otherwise  $R(\psi \rightarrow \phi) = 0$ .

$\text{Sym}_G(\rho) := \{g \in G \mid \mathcal{U}_g(\rho) = \rho\}$  ( $\approx$  periods)

[In our paper, formula is extended to any compact Lie group]

Prior studies: only few examples

- U(1): pure states w/ the same periods  
[Gour-Spekkens (2008)] [Marvian (2022)]
- SU(2): specific sets of pure states  
[Gour-Spekkens (2008)]
- SO(3): specific sets of pure states  
[Yang-Chiribella-Hu (2017)]
- Marvian-Spekkens conjecture:  
condition for reversible conversion  
[Marvian-Spekkens (2014)]

} Separate analyses  
of  
specific examples

} Unresolved for  
over a decade

Our result: general theory

- **Any** compact Lie group
- **Any** pure states
- Both **reversible and irreversible** conversion
  - MS conjecture is proven as a corollary

[KY, Y. Mitsuhashi, T. Shitara, and H. Tajima arxiv:2411.04766]

Our formula significantly extends and unifies previous work and resolves a long-standing conjecture.

# Application to quantum thermodynamics

For simplicity, we will focus on time-translation symmetry.

Thermal operation: interaction w/ thermal bath

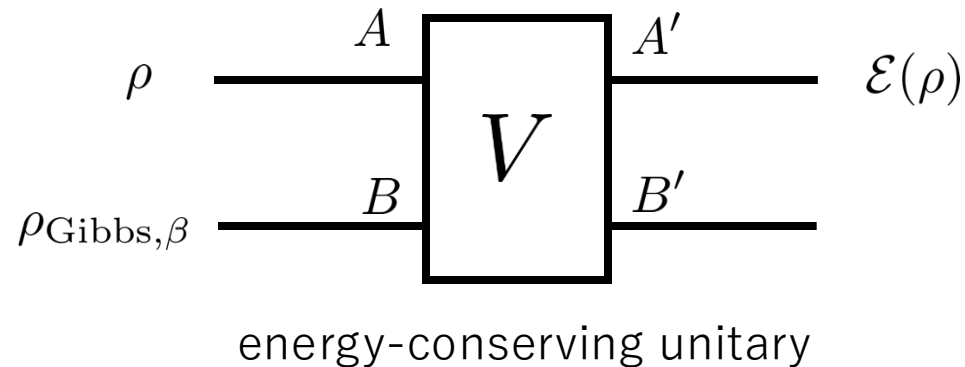

$\rho_{\text{Gibbs},\beta}$  is a symmetric state

$\Rightarrow$  any thermal operation is a covariant operation

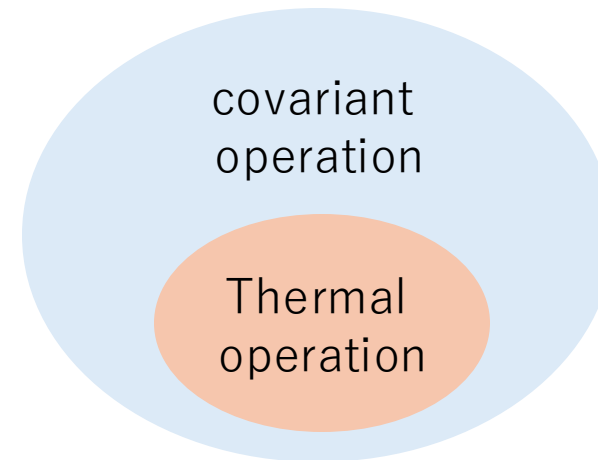

- Thermal operations cannot generate energy coherence.
- An incoherent state cannot be converted to a coherent states via thermal operations.
- How much coherence is required to enable such conversions?

# Coherence requirement for reversibility

A generalized scenario: thermal bath + coherence source

“The amount of required coherence” is quantified by the energy range  $\|H_{C_N}\|_\infty$  of the coherence source system  $C_N$ .

Reversible conv. can be achieved with  $C_N$  s.t.  $\lim_{N \rightarrow \infty} \frac{\|H_{C_N}\|_\infty}{N} = 0$

[P. Faist, T. Sagawa, K. Kato, H. Nagaoka, and F. G. Brandão (2019)]

[T. Sagawa, P. Faist, K. Kato, K. Matsumoto, H. Nagaoka, and F. G. Brandão (2021)]

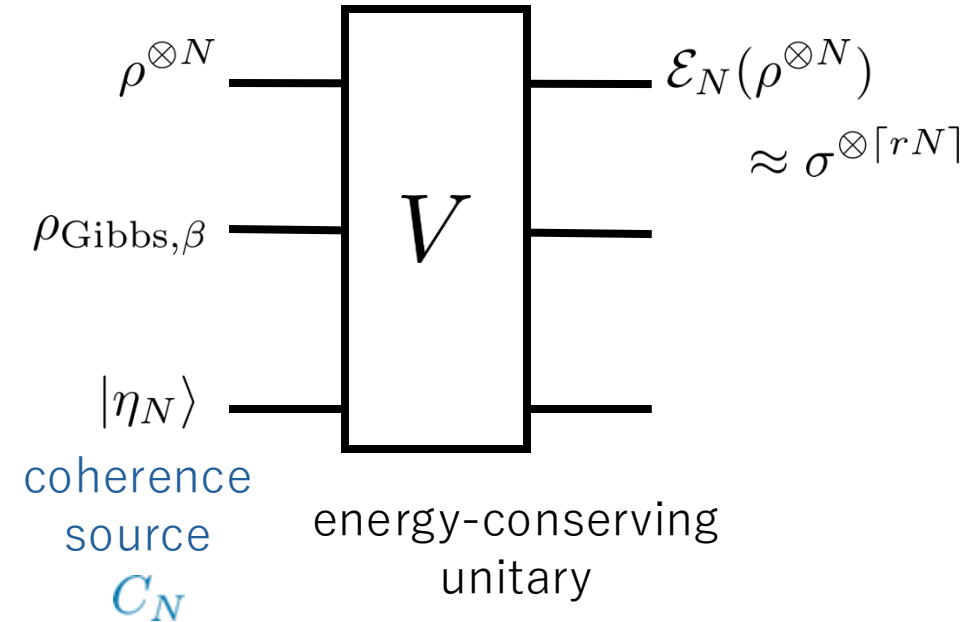

$\|H_{C_N}\|_\infty$  does not depend on the state  $|\eta_N\rangle$ , which therefore cannot be detailed information of coherence.

**Can we obtain more refined information by adopting the QGT as a measure of coherence?**

# Macroscopic coherence required for reversibility

A generalized scenario: thermal bath + coherence source

QGT for time-translation symmetry = energy variance

$$\text{Var}(\psi, H) := \langle \psi | H^2 | \psi \rangle - \langle \psi | H | \psi \rangle^2$$

- Consider
- $\rho$  is full-rank
  - $\psi$  is a pure state

If  $\rho$  is convertible to  $\psi$  with a rate  $r > 0$ , then

$$\lim_{N \rightarrow \infty} \frac{\text{Var}(\eta_N, H_{C_N})}{N} \geq r \text{Var}(\psi, H)$$

In particular, when we prepare coherence bits as a coherence source, we need  $O(N)$  such bits.

**In quantum thermodynamics,  
there are infinitely many cases in which macroscopic coherence is required for state conversion.**

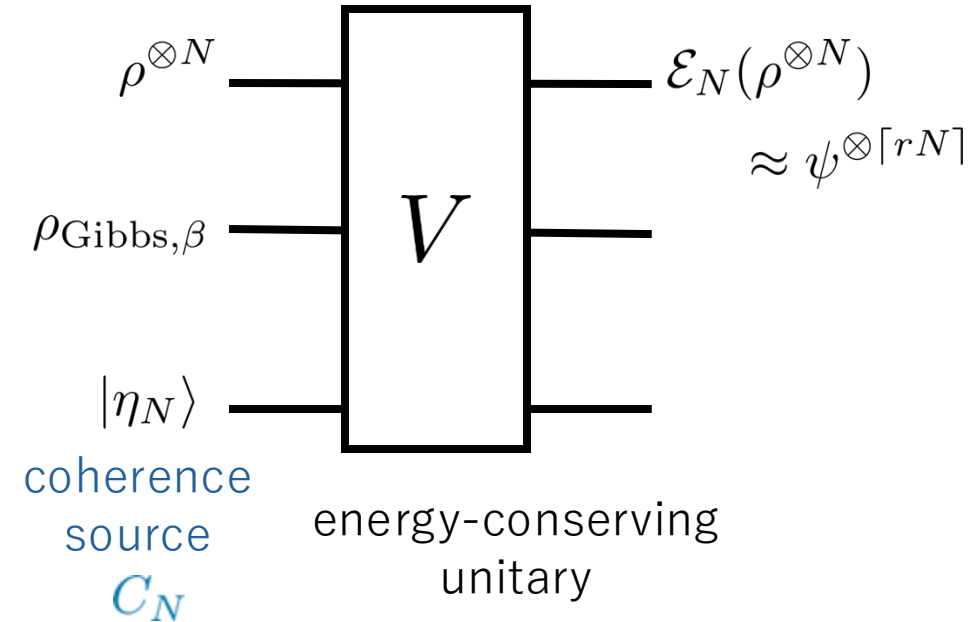

# Summary

- We have established the IID conversion theory in the RTA for any continuous symmetry described by a compact Lie group
- The QGT is the standard measure of asymmetry (i.e., the symmetry breaking of a state).
- Quantifying the coherence (i.e., time-translation asymmetry) with the QGT, we showed that a macroscopic amount of coherence is required for asymptotic conversion in quantum thermodynamics
- Takeaway: Let's quantify symmetry breaking with the QGT!